

**PARTS LIST FOR 5 FT. TOWER / SINGLE BLIND**

<u>Quantity</u>	<u>Part No.</u>	<u>Description</u>
4	L	1 ½" Angle Legs
4	N	1" Angle Horizontal Braces
8	O	1/8" x ¾" Flat Diagonal Braces
2	P	¾" Angle Ladder Runners
4	Q	¾" Angle Ladder Rungs
4	J	1 ½" Angle Foot
8	K	Tower Anchor Clips
1	U	Hand Bar
55	Bolt	¼" x ¾" Bolt
55	Lock Washer	¼" Split Lock Washer
55	Nut	1/8" Hex Nut
2	U Bolt	5/16" 'U' Bolts w/Hardware to Secure Ladder to Tower Braces

**USE AT YOUR OWN RISK**

Blinds and Towers must be  
 Properly assembled and  
 Anchored to the ground.



## ASSEMBLY INSTRUCTIONS FOR THE 5 FT. TOWER/SINGLE BLIND

**Note: Do not tighten any bolts in the Tower assembly until all bolts are installed.**

1. Remove the (K) clips from this package and assemble the blind, being sure to install these clips according to the blind instructions. (Fig. 1)
2. Lay the blind on its side with the door facing up, protecting it with the cardboard packaging. Raise the bottom of the blind (floor-end only) 10 - 14 inches off the ground with a support.
3. Attach the (U) handle to the (S) corner post nearest the door opening. Remove the first and second bolts from the bottom of the (S) corner post. Position the (U) handle and attach by reinstalling the bolts. (Fig. 1)
4. Attach the (L) Legs to (K) K-Clips using (N) Horizontal Bracing as necessary for support. (Fig. 1)
5. Complete the tower by adding all braces as shown. (Fig. 2 & Fig. 3)
6. Attach the (J) Feet as shown. (Fig 2)
7. Assemble & install the ladder using bolts and U-bolts as pictured. Attach top two holes in ladder runners using existing bolts used to attach the "Z" plate, underneath the blind (opposite the "Z" and behind the angle iron supporting the floor). (Fig. 4)
8. Tighten all bolts/nuts.
9. **After raising the blind/tower into position, it must be anchored.**

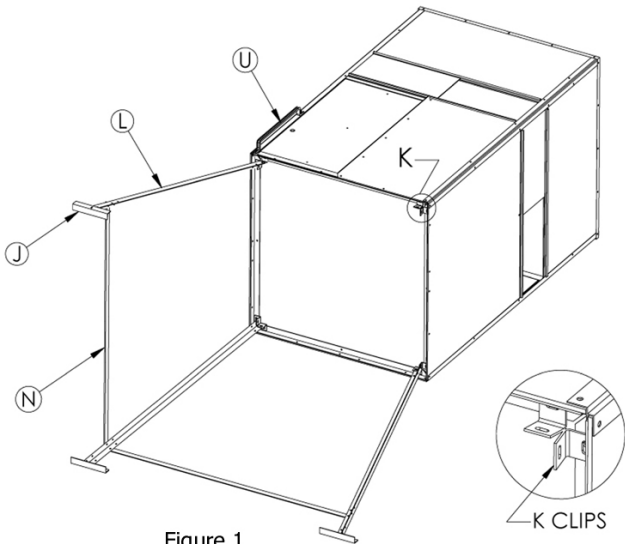

Figure 1

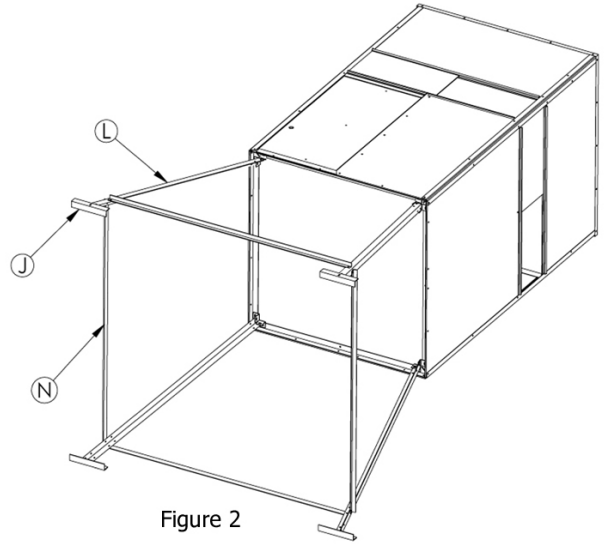

Figure 2

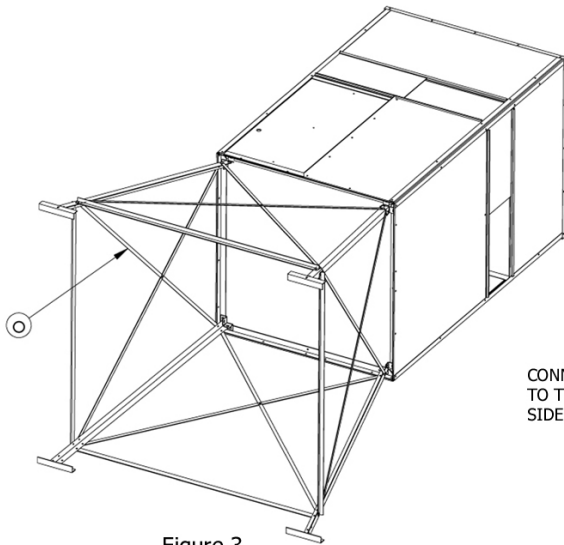

Figure 3

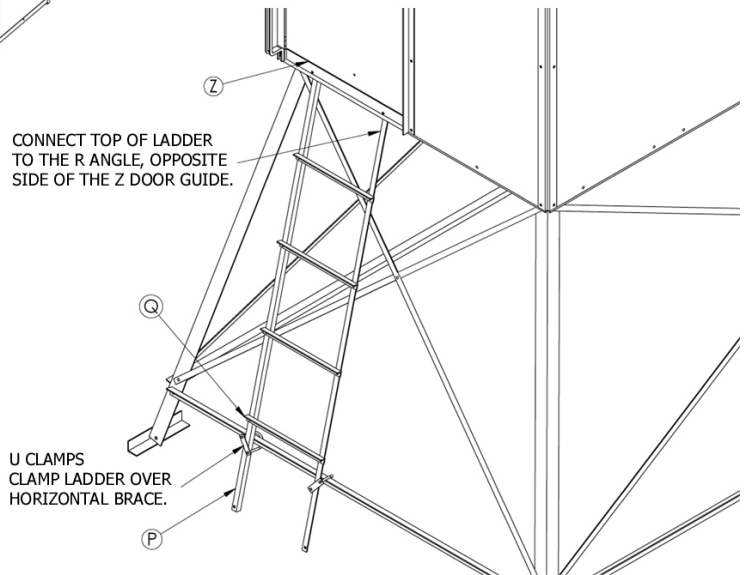

Figure 4

# PART ORIENTATION QUICK REFERENCE

